

# The Howard Banta Alarm Clock Chapter



Chapter 178 of the National Association of Watch and Clock Collectors

www.acc178.org

July 2015

## **COME TO THE REGIONAL IN RENO ON AUGUST 29 AND 30 TO MEET AND SPEAK WITH OUR CHAPTER PRESIDENT**

### Presidents' Message

I would like to share something with the members of the Alarm Clock Chapter. Recently I have taken on the job as Chairman of the Silver Dollar Regional this coming August in Sparks, Nevada.

I have Chaired this position twice before in 2006 and 2010. This year I have had input in most of the events that will take place at the Convention. Most recently I have been helping Tom Bartels, Chair of the Exhibit, with the planning of the Exhibit.

In doing so I discovered that at this time in my life I have pretty much the collection I have always wanted with the exception of a few. Part of the reason is that finding and selling alarm clocks is now much harder than the last 25 years of my collecting. Part of that reason is there are not as many great alarm clocks for sale even though the prices have come down in the past few years as have everything else.

I now realize that more importantly than buying any and all the alarm clocks I see, it is more likely that I will now pass up many alarm clocks today that I would not have passed up previously. I still love collecting and will always collect whether it is alarm clocks or salt and pepper shakers for example.

I believe now "the hunt" is the reason I still go out to garage sales, flea markets and clock conventions. Even if I go to a Convention and only buy one alarm clock I have had the time of my life. I am able to search out all avenues, learn more by listening and make it a social event rather than that intense search that we all have had.

Now that we all have basically our collection we should embrace what we have collected and it is now the time to share what we have to the point of even displaying a small display of alarm clocks at our Convention table or participate in Exhibits at Convention.

We might think that our collection is somewhat "common" but more likely it is the very interesting to most who see it.

Keep on searching and sharing. That will keep the collecting alive and vibrant.

Vince

### IN THIS ISSUE

- |                 |  |
|-----------------|--|
| <b>Page 1</b>   | <b>President's Message</b>                                     |
| <b>Page 2-5</b> | <b>Article and Pictures of the Peep-O-Day alarm by Ansonia</b> |
| <b>Page 6-7</b> | <b>Some rare German clocks</b>                                 |
| <b>Page 8-9</b> | <b>A Westclox Alarm with pasted over dial</b>                  |
| <b>Page 10</b>  | <b>Flyer for the Reno Regional</b>                             |

### EDITOR'S NOTE

#### **WITH OUT YOUR HELP THERE WILL BE NO NEWSLETTER**

As always I need material for the newsletter. If you have an unusual or interesting alarm clock or any related material please send me pictures and a short write up so it can be included in a future newsletter. Send information to [rlink3@juno.com](mailto:rlink3@juno.com) or mail it to:

Chapter 178  
7186 Calico Circle  
Corona, Ca. 92881

**Editor's Note: My thanks to Vince Angell for the following article and pictures.**

## **The Ansonia Peep O' Day Alarm Clock Ca 1877**

As many of us alarm clock collectors know Ansonia Clock Company made countless alarm clocks. Some of which are very common and others are more collectable. One collectable alarm clock from Ansonia has a very special movement call the Peep O' Day movement. As can be seen in one of the following pictures the Peep O' Day's trademark is very distinctly stamped into the case.

This movement was patented on March 27, 1877 by H.J. and W.D. Davies. The patent allowed the movement to have only one spring doing the function of both the time side and the alarm side of the clock. You just wind the one winding key seen on the back and this allowed the clock to keep time and at the designated hour ring the alarm.

The following are a couple of possible reasons that this movement is called the Peep O' Day by the owners of the Ansonia Clock Company.

The first idea comes from a fellow Davies collector. He states: "...that the Merchant Princes of the time were known as Peep O' Days because of their interest in shipping.... Peep O' Day means, of course, the very first light of day. William Dodge is the definition of a "Merchant Prince". Both the father and the son were the key partners in Phelps & Dodge Company. This is the company that owned the Ansonia Brass and Copper Company and the Ansonia Clock Company. I think they also hired Peep O' Day boys to keep track of shipping for them, as fortunes could be made by both knowing what a ship was carrying and being the first to buy its cargo.

The first mention of Peep O' Day boys as I recall was with Anson Phelps out in the early morning watching for ships arriving in New York through the Hudson River..."

Another idea associated with the name Peep O' Day could be from an alarm clock collector that knows of a "rumor" .....The Peep O' Day alarm clock in this article is his. His thought was that the center of the dial of his Peep O' Day appears to be a view through a telescope of what he would like to think was the Hudson River. Several years ago another NAWCC member suggested the term "Peep O' Day" came from lookouts waiting for ships to come into sight so they could alert the local community that the ship was arriving with supplies.

Believe what you may as to which explanation is the correct one. I, personally, do not think that either is correct but actually both seem to have similarities that lead me to believe what I say many times:

"There's always a little truth in everything."

Just enjoy the pictures of a great alarm clock  
And the stories that are associated with it.

We wish to thank members Ronald Hoops and John Koepke for their interesting stories and pictures.

Vince Angell



THE PEEP-O DAY ALARM BY ANSONIA



H. J. & W. D. DAVIES.

ALARM CLOCK.

No. 188,865.

Patented March 27, 1877.

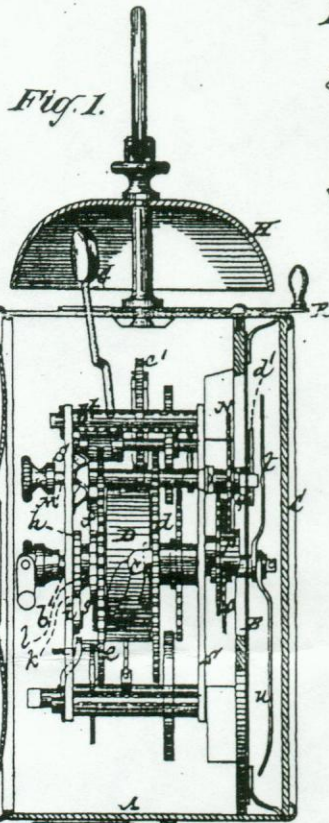

Fig. 1.

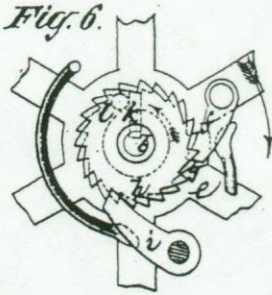

Fig. 6.

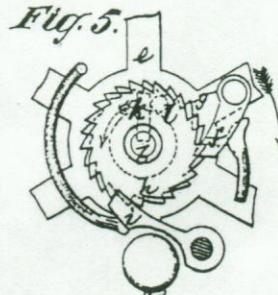

Fig. 5.

Fig. 2.

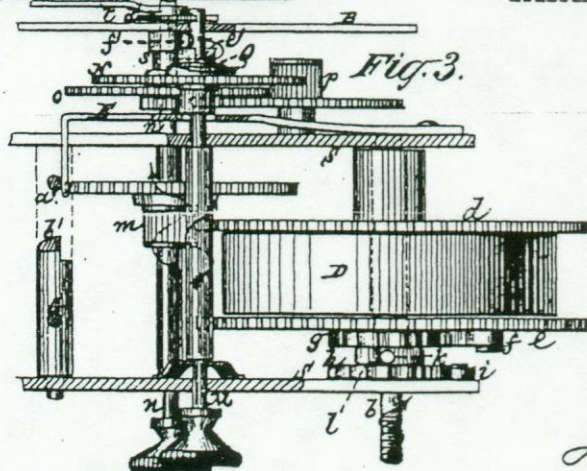
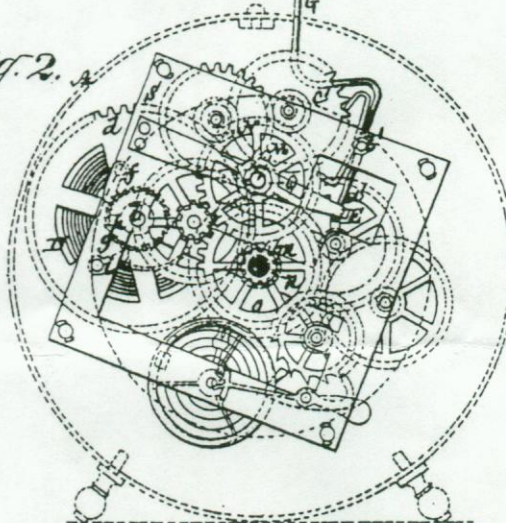

Fig. 3.

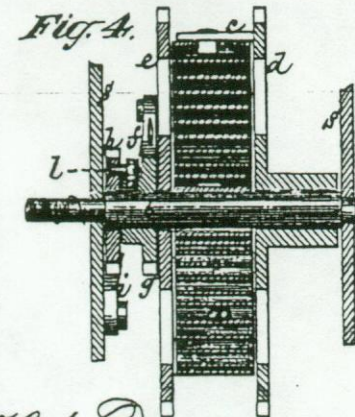
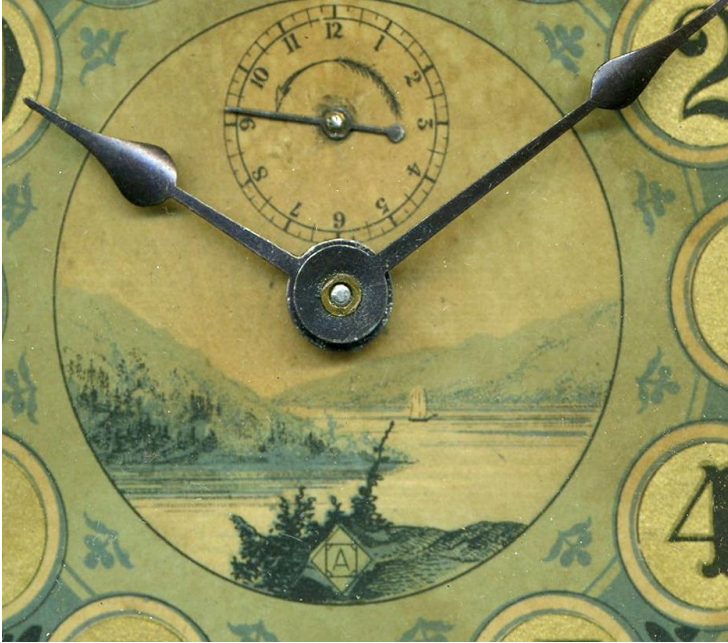

Fig. 4.

Witnesses  
John Becker  
Fred Meyer

H. J. Davies  
W. D. Davies  
By *Arthur O. Horner*  
Brown & Allen





A close up of the Peep-O-Day dial



Back of the Peep-O-Day. Notice there is only one winding knob. The small arrow just visible at the 6:00 o'clock is the timing regulator

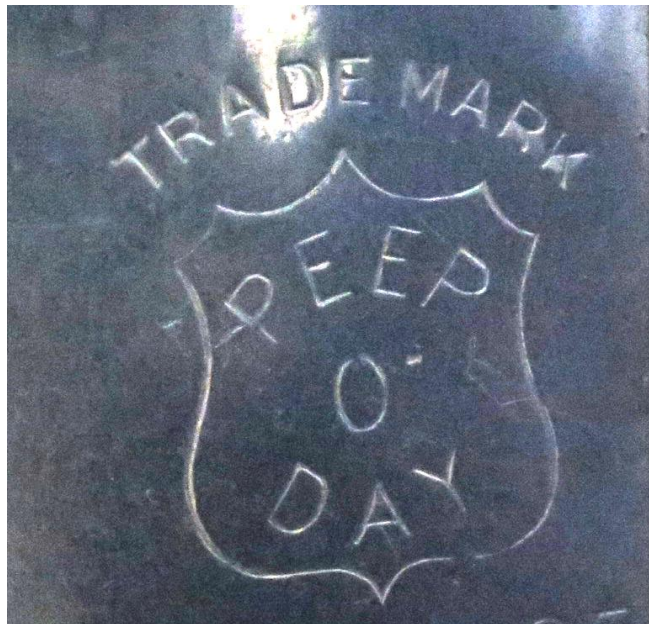

Peep-O-Day logo

**Editor's Note: *The following items are not intended to offend anyone but are offered only in their historical content.***

## **More Rare Alarm Clocks From "Alarm Clock Peter"**

I believe that Alarm Clock Peter is probably not just one of the biggest collectors of German alarm clocks in Germany but probably the biggest collector.

He is always on the hunt for unusual alarm clocks even planning his trips and vacations in areas that he knows will have flea markets and antique shows where the unusual show up. As we have shown in past HBACC Newsletter we see that his level of collecting far surpasses many of the alarm clock collectors that I know. From the simple, but unusual, alarm clock to some that have multiple bells or animation of the strikers.

He recently shared with me photos of extremely rare German animated alarm clocks. These were not just the "run of the mill" alarm clocks but a specific of alarm clocks that are highly collectible both with clock collectors and other collectors.

We here in the United State refer to this collectable as "Black Americana". Clocks that were made back in the early 1900's but would never be made today for obvious reasons. That being said, many people still collect Black Americana items today because of their rarity of the items and to show what the mindset was in the early part of the 1900's.

**The following alarm clocks are prized by many and very collectable.**





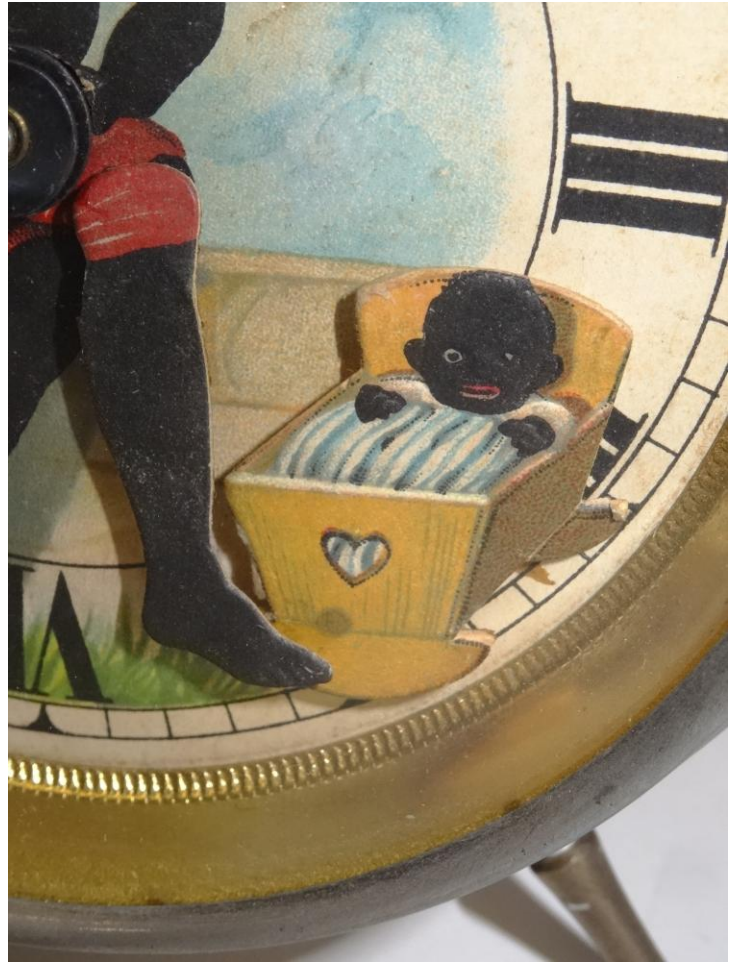

## A Westclox Alarm with a Pasted Over Dial

Our Treasurer / Secretary Mike Wilson has sent me pictures of a recent acquisition he made. The Clock measures 5 inches wide by 4 ¾ inches high and from the shape is surely a Style 8 Westclox Big Ben alarm clock from the late 1960's or sometime in the 1970's. The dial has a pasted over label with the image of a Harley Davidson motorcycle. It also clear that the case has been repainted (see image on next page).

The question to ask is just who was it that made the alterations. Was it done by Harley Davidson (it is hard to believe a corporation this large would have done it)

or maybe one of its Distributors?

In any case this is an unusual find and I thank Mike for sharing it with us.





## Back of the Alarm



It is quite faint but if you look closely you will see the Westclox label stamped on the lower left corner of the back. It has obviously the label has been painted over. Again this ask the question who made the alterations.



# The Silver Dollar Regional - Reno/Sparks, NV

**Saturday, August 29 & Sunday, August 30, 2015**

**Host Hotel: The Nugget Casino and Resort**

**1100 Nugget Avenue, Sparks, Nevada**

Come Early – Stay Late. Reno/Sparks is a Great Place for a Mini-Vacation.  
Contact The Nugget, 1-800-648-1177 for Rooms, Show Packages & Free Airport Shuttle

**Mention GWATCH for Convention Room Rates**

**\$79/night Fri-Sun in The Nugget West Tower**

For more info, check the Web Sites: [WWW.JANUGGET.COM](http://WWW.JANUGGET.COM) and The Visitor & Convention Center, [WWW.VISITRENOTAHOE.COM](http://WWW.VISITRENOTAHOE.COM)

**Tentative Schedule:**

**Friday Evening, August 28** - Pre-Registration Pick-Up Only - 5:30 PM – 7:30 PM  
Hospitality – “Meet Your Neighbors” - 8 PM – 10 PM

**Saturday, August 29**

Registration 8:00 AM - 6:00 PM  
Mart Set-Up 9:00 AM - 12:00 NOON  
Early Bird Entry 9:00 AM - 12:00 NOON  
Mart & Exhibit Open 12:00 NOON- 6:00 PM

**Features:**  
Fully Carpeted Mart Room  
Early Bird Entry  
10 Minute University Programs in Mart Room

**Sunday, August 30 – Mart Open to Public**

Breakfast Banquet \*7:30 AM – 9:00 AM \*Time Change  
Registration 9:30 AM – 3:00 PM  
Mart Open 10:00 AM – 4:00 PM  
Security Ends 5:00 PM

**Check out:**  
[www.silverdollarregional.org](http://www.silverdollarregional.org)

Free Porter Service Available for Unloading / Loading  
Saturday 8:30AM–11AM / Sunday 3PM–5PM

**\*A Special Table Holders 2(two) \$200 Cash Drawings will be held on Sunday at 3:00PM – (Must be present and set up to win)**

-----Please Print Clearly-----

**Pre-Registration Form – Deadline: Postmarked By August 10, 2015**

Name \_\_\_\_\_  
 NAWCC Number \_\_\_\_\_ [ ] Fellow, [ ] Old Timer, [ ] Silver Star, [ ] National Officer  
 Spouse's Name \_\_\_\_\_ NAWCC Number \_\_\_\_\_  
 Children (Names) \_\_\_\_\_  
 Address \_\_\_\_\_ Phone (\_\_\_\_) \_\_\_\_\_  
 City \_\_\_\_\_ State \_\_\_\_\_ Zip \_\_\_\_\_  
 Email Address \_\_\_\_\_

	Advance Rate to August 10, 2015	Total	Rate after August 10, 2015 & at the Door
Registration (Member)	_____ @ \$30.00	\$ _____	\$35.00
Spouse	_____ @ \$25.00	\$ _____	\$30.00
Children Under 18	_____ FREE		
Early Bird Entry	_____ @ \$25.00	\$ _____	\$25.00
Mart Tables (6 Foot Tables)	_____ @ \$35.00	\$ _____	\$40.00 if Available
Breakfast Banquet	_____ @ \$20.00	\$ _____	\$20.00 if Available
<b>TOTAL ENCLOSED →</b>		\$ _____	

**Mail Registration Form and Check, payable to “DVC 107 NAWCC/2015 Silver Dollar Regional”**

**Mail to: John Koepke, PO Box 21263, El Sobrante, CA 94820 (jskoepke@comcast.net)**

The Fine Print: All NAWCC Mart Rules & Nevada Sales Tax Regulations Apply. Maximum of 2 Adult Registrations per Table. Multiple tables booked by groups must be sent in the same envelope to ensure group placement. Only Horological items may be sold at the Mart. Only NAWCC Members, their spouses & their children under 18 with valid registration badges will be admitted to the Mart. You must show a current NAWCC card to get your entry badge and registration package. The NAWCC, its officers and members, and The Silver Dollar Regional members and Chapters 65,107 & 5 Officers and Directors are not responsible for any loss, damage or injury or tort during or associated with this event.

Hosted by The Sierra Nevada Chapter #65, Diablo Valley Chapter #107 & Dr. Barclay Stephens Chapter #5  
 Mart Chair: Bob Peischl, [uhrhaus@aol.com](mailto:uhrhaus@aol.com) Regional Chair: Vince Angell, [phylathome@hotmail.com](mailto:phylathome@hotmail.com)